

GENERAL DESCRIPTION

The Sellers atmospheric .005 deaerators condition make-up water and condensate returns to convert them into more desirable boiler feedwater. Super heating and atomization are used to remove oxygen and carbon dioxide before the water is pumped to the boiler. Atmospheric deaerators are desirable when high make-up percentages or gravity returns are anticipated.

MODEL DESCRIPTION

MODEL .005 SINGLE TANK

The single tank .005 cc/liter atmospheric deaerator is a complete factory assembled system. It offers simplicity in operation and service, and assures effective removal of oxygen to a level not to exceed .005 cc/liter. This system operates by mixing pumped returns and fresh water make-up and super heating them to 220 degrees F. in an external heat exchanger. The water is then admitted into the atmospheric storage tank through spring loaded spray nozzles for atomization. This fine mist will immediately flash to steam, resulting in the complete separation of oxygen and other non-condensable gases. The vapor then enters an externally mounted vent condenser. As the water falls to storage in the receiver, the oxygen and other gases are released through the unrestricted vent.

A pneumatic or float type modulating level controller and valve admits fresh make-up as needed to maintain a minimum water level. Small quantities (up to 5%) of high temperature (over 212° F) gravity returns can be dropped directly in to the receiver through the top baffled opening. Other low temperature returns should be pumped at 15 psi minimum.

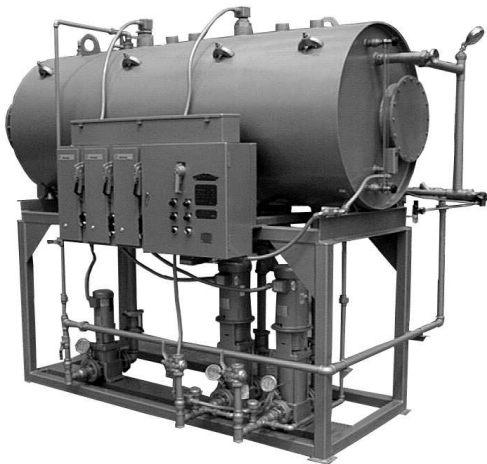

MODEL DK5 SPLIT TANK

The DK5 split tank atmospheric deaerator provides one large receiver with an internal baffle that splits the tank into two sections. Make-up and low temperature returns (gravity or pumped) are brought back to the surge section. High temperature condensate is returned to the deaerator section. This system is very versatile and can be used in most applications that have a blend temperature of less than 180° F. With the split tank design, the need for a separate condensate set to pump back to the deaerator is eliminated because it can accept gravity returns.

A transfer pump is provided to constantly move water from the surge section to the deaerator section for heating. The water is heated to 220° F. through an externally mounted heat exchanger and then enters the receiver through spray nozzles. Excess water not used by the boilers overflows back and preheats the surge section. This also provides recirculation of the stored water in the deaerator section to ensure constant .005 deaeration.

An internal vent condenser and spray bar in the surge section condenses the steam. The oxygen and non-condensable gases are vented to atmosphere.

A float or solenoid type valve with level controller is provided to admit fresh make-up as needed to maintain a minimum water level.

MODEL K5 SPLIT TANK

The K5 model is also available. It operates similar to the DK5, however a pneumatic valve modulates flow from the transfer pump to maintain proper level in the deaerator section. When the water reaches the proper level, the transfer pump is de-energized. This feature can save energy in many applications.

Dimensionally and functionally this system is the same as the DK5 system. The differences being the transfer valve on the K5 system and the constant recirculation on the DK5 system.

.005 DEAERATORS – ATMOSPHERIC

MODEL NUMBER SELECTION

The model number is composed of the base system type and the total boiler horsepower plus the number and type of boiler feed pumps plus the heating assembly model.

Example:

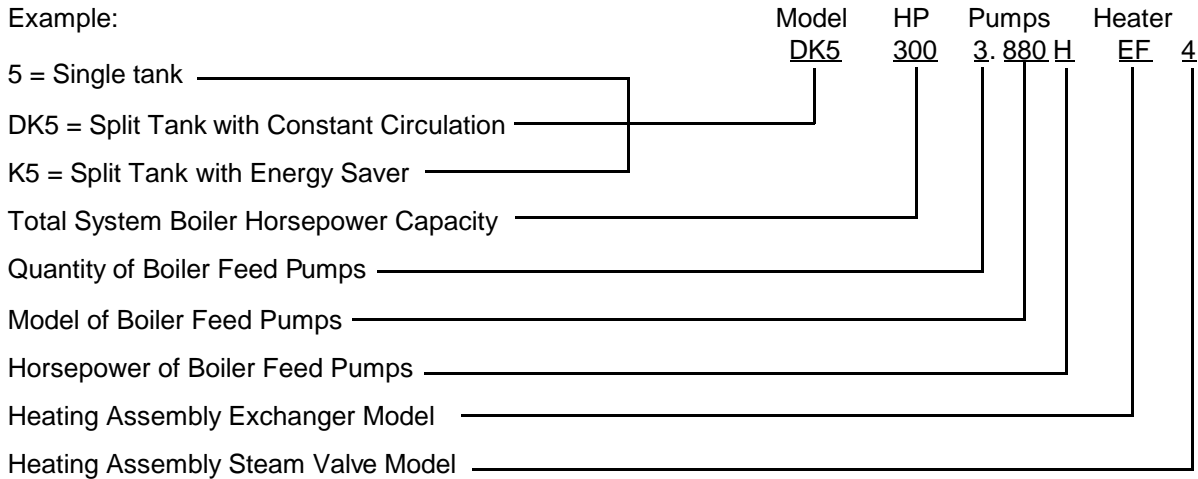

SELECTION INFORMATION

Model types are described on page 1 and on model description sheets.

Horsepower refers to total system boiler capacity. This determines the size of the spray bar, the openings, the overflow, the transfer pump and the standard tank. If larger tanks are

desired, specify the correct system horsepower and the required tank size.

Only boiler feed pump models are shown. The transfer pump for a split system is determined by the system horsepower capacity.

.005 HEATER ASSEMBLY SELECTION

The heater assembly should be sized to take care of the total input load to the system. Make-up water and all low temperature returns require heating. High temperature returns and drips coming back at over 212° degrees F. do not

need to be heated and should be admitted below the water line through an optional diffuser tube. See below for an example of how to size and select the proper heating assembly.

STEP 1

Calculate tank blend temperature and required heat rise based on minimum temperature input.

EXAMPLE

Total load: = 300 HP (10,350 lbs/hr).....20.7 GPM
 Minimum steam supply pressure.....75 psig
 25% make-up at 40° F.....5.18 GPM
 70% L.P. pumped returns at 150° F.....14.5 GPM
 5% returns at 320° F. (heating not required – provide diffuser tube.)

.25 x 40 = 10° F.
 .70 x 150 = 105° F.

Blend temperature = 115° F. (sum)

Required temperature rise = 220° – 115° = 105° F.

STEP 2

Select heating assembly steam valve based on the steam supply pressure and required flow in lbs/hr.

Calculate the required lbs/hr using the following formula:

$$\text{Steam Required} = \frac{\text{GPM} \times 500 \times \text{Temperature Rise}}{936}$$

Where: GPM = Total system flow (HP X .069)
 500 = Conversion factor
 Temperature rise = From Step 1
 936 = Latent Heat of Steam @ 22 psi

Example: $\frac{20.7 \times 500 \times 105}{936} = 1,161.06 \text{ lbs/hr}$

See chart on page 3 to select valve and exchanger.

.005 SINGLE TANK ATMOSPHERIC DEAERATOR

CAPACITIES

Base system model is selected from the following table. The model selected should be suitable for the

total system design horsepower load or total boiler load in pounds of steam per hour.

MODEL NUMBER	POUNDS STEAM PER HOUR	GALLONS PER MINUTE	RECEIVER SIZE (INCHES)	CAPACITY TO OVERFLOW		MAKE-UP VALVE MODEL	SHIPPING WEIGHT* POUNDS
				GALLONS	MINUTES		
5-100	3,450	6.9	30 X 50	120	17.4	MM51S	1,010
5-150	5,175	10.4	30 X 50	120	11.5	MM51S	1,010
5-200	6,900	13.8	30 X 50	120	8.7	MM51S	1,010
5-250	8,625	17.3	30 X 84	200	11.6	MM51S	1,300
5-300	10,350	20.7	30 X 84	200	9.7	MM51S	1,300
5-350	12,075	24.2	30 X 104	250	10.3	MM51S	1,470
5-400	13,800	27.6	36 X 84	310	11.2	MM51S	1,560
5-500	17,250	34.5	42 X 84	430	12.5	MM51S	1,770
5-600	20,700	41.4	42 X 84	430	10.4	PM3	1,770
5-800	27,600	55.2	42 X 104	540	9.8	PM3	2,050
5-900	31,050	62.1	42 X 104	540	8.7	PM3	2,050
5-1000	34,500	69.0	48 X 104	720	10.4	PM3	2,610
5-1200	41,400	82.8	48 X 120	830	10.0	PM3	2,990
5-1500	51,750	103.5	54 X 120	1,070	10.3	PM3	3,320
5-1800	62,100	124.2	60 X 120	1,340	10.8	PM3	3,840

*Does not include pumps or heating assembly.

STANDARD EQUIPMENT FURNISHED

Receiver: Single tank with handholes or manhole.

Temperature Gauge: Two 3" diameter dial type.

Epoxy Lining: Receiver is sandblasted and lined.

Pressure Gauge: Two 4-1/2" diameter dial type.

Stand: Welded structural steel.

Overflow Trap: Includes syphon breaker.

Make-up Valve: Standard is sized for 25% of capacity.

Drain Valve: Pre-piped to overflow line.

Make-up Controller: Pneumatic on 600 HP and larger.

Steam Valve: Controls temperature and pressure with pneumatic valve.

Bypass: Three valve around make-up valve.

Steam Strainer: Screwed or flanged to match valve.

Vent Condenser: External shell and tube type.

Heat Exchanger: Externally mounted to heat make-up and returns to 220° F.

Low Water Alarm: Two probe type to stop pump and sound alarm.

Control Panel: UL Listed assembly.

Spray Bar: Stainless steel spray bar and nozzles.

Factory Assembly: Complete package system ready for connection of utilities.

Air Filter Regulator: Maximum 100 psig inlet.

Boiler Feed Pumps: See Pump Bulletin.

Water Gauge Glass: Brass safety type with check.

.005 SINGLE TANK ATMOSPHERIC DEAERATOR

DIMENSIONS

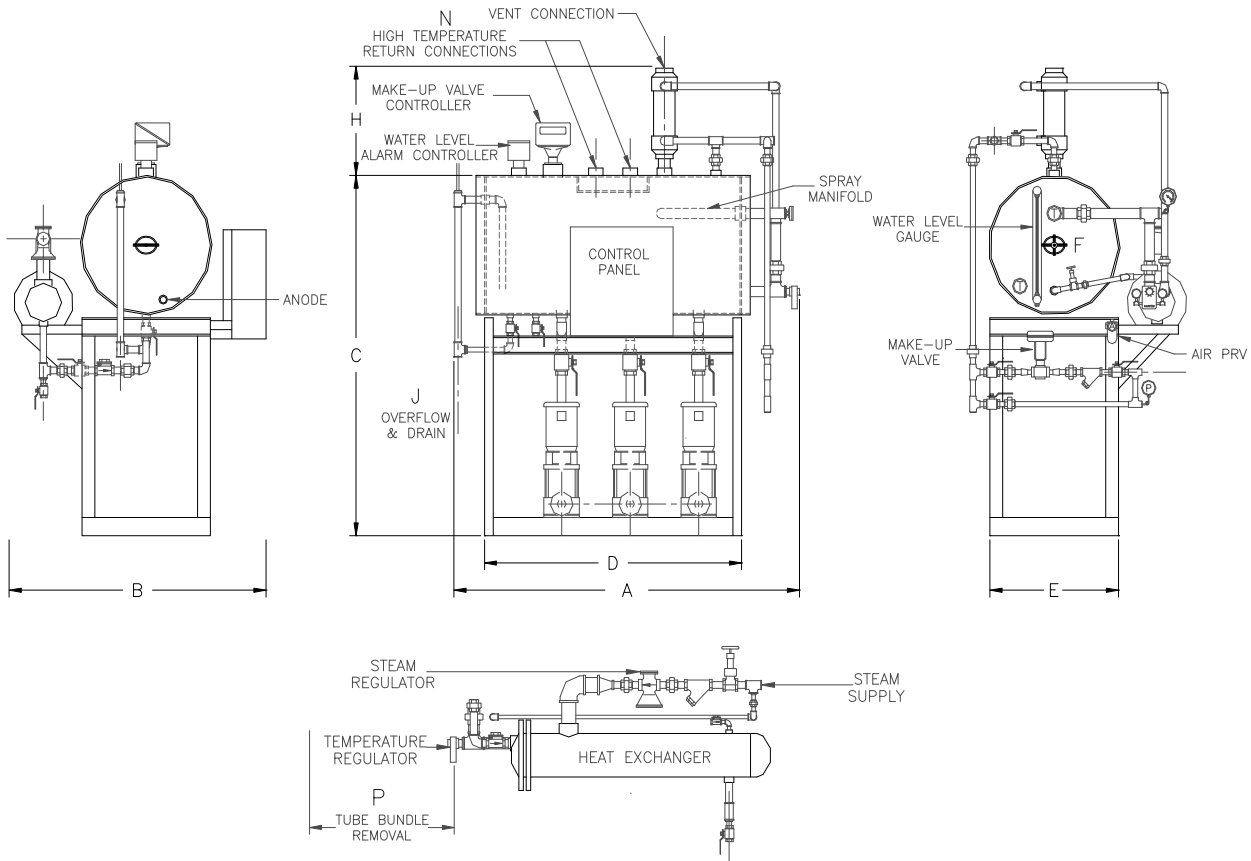

MODEL NUMBER	A	B	C	D	E	F	H	J	K	N	P	Q
5-100	68	53	78	54	30	--	22	1.25	0.75	1.5	50	1.25
5-150	68	53	78	54	30	--	22	1.25	0.75	1.5	62	1.25
5-200	68	58	78	54	30	--	22	1.5	0.75	1.5	50	1.25
5-250	102	58	78	88	30	--	22	1.5	0.75	2	50	1.5
5-300	102	56	78	88	30	--	22	1.5	0.75	2	62	2
5-350	122	56	78	108	30	--	22	1.5	0.75	2	75	2
5-400	102	62	84	88	36	X	22	2	0.75	2.5	75	2
5-500	102	70	90	88	42	X	32	2	0.75	2.5	62	2
5-600	102	70	90	88	42	X	32	2	1	3	75	2.5
5-800	122	70	90	108	42	X	34	2	1	3	98	2.5
5-900	102	68	90*	108	42	X	34	2.5	1	3	88	2.5
5-1000	102	76	96*	108	48	X	34	2.5	1	4	88	2.5
5-1200	138	76	96*	124	48	X	44	2.5	1	4	88	3
5-1500	138	85	102*	124	54	X	44	3	1	4	88	3
5-1800	138	85	108*	124	60	X	35	3	1	4	98	3

NOTES:

- (1) Overall dimensions could vary depending on options furnished.
- (2) Refer to submittal drawings for system height with condenser.
- (3) See submittal drawing for vent line and steam supply sizes.
- (4) Make-up supply line to valve inlet should be a minimum of one pipe size larger than valve.
- (5) Pump orientation is typical. Quantity and type of pumps will determine final orientation.
- (6) Stand height may increase to accommodate pump NPSH.
- (7) Insulation not included in width dimensions.

*Consult factory for over height shipping arrangements.

DK5 (K5) SPLIT TANK ATMOSPHERIC DEAERATOR

CAPACITIES

Base system model is selected from the following table. The model selected should be suitable for the

total system design horsepower load or total boiler load in pounds of steam per hour.

MODEL NUMBER	POUNDS STEAM PER HOUR	GALLONS PER MINUTE	RECEIVER SIZE (INCHES)	CAPACITY TO OVERFLOW**		MAKE-UP VALVE MODEL	SHIPPING WEIGHT* POUNDS
				GALLONS	MINUTES		
DK5-100	3,450	6.9	36 X 50	180	26.1	M51S	1,660
DK5-150	5,175	10.4	36 X 50	180	17.3	M51S	1,720
DK5-200	6,900	13.8	36 X 84	310	22.5	M51S	2,060
DK5-250	8,625	17.3	36 X 84	310	18.0	M51S	2,060
DK5-300	10,350	20.7	36 X 104	380	18.4	M51S	2,260
DK5-350	12,075	24.2	36 X 104	380	15.7	M51S	2,260
DK5-400	13,800	27.6	42 X 104	540	19.6	M51S	2,550
DK5-500	17,250	34.5	48 X 104	720	20.9	M51S	3,050
DK5-600	20,700	41.4	48 X 104	720	17.4	E3	3,360
DK5-800	27,600	55.2	60 X 104	1,160	21.0	E3	4,200
DK5-900	31,050	62.1	60 X 104	1,160	18.7	E3	4,200
DK5-1000	34,500	69.0	54 X 140	1,220	17.7	E3	4,490
DK5-1200	41,400	82.8	60 X 140	1,520	18.4	E3	5,110
DK5-1500	51,750	103.5	66 X 140	1,870	18.1	E3	5,850
DK5-1800	62,100	124.2	66 X 158	2,170	17.5	E3	7,190
DK5-2400	82,800	165.6	72 X 185	2,890	17.5	E4	9,960
DK5-3000	103,500	207.0	72 X 212	3,410	16.5	E5	10,880
DK5-4500	155,250	310.5	84 X 255	5500	17.7	E6	12,610

*Does not include pumps or heating assembly. **55% in surge section, 45% in DA section.

STANDARD EQUIPMENT FURNISHED

Receiver: Single tank with handholes or manhole.

Pressure Gauge: Two 4-1/2" diameter dial type.

Epoxy Lining: Receiver is sandblasted and lined.

Overflow Trap: Includes syphon breaker.

Stand: Welded structural steel.

Drain Valve: Pre-piped to overflow line.

Make-up Valve: Standard is sized for 25% of capacity.

Steam Valve: Controls temperature and pressure with pneumatic valve. Provided with steam strainer.

Make-up Controller: Pneumatic on 600 hp and larger.

Heat Exchanger: Externally mounted to heat make-up and returns to 220° F.

Bypass: Three valve around make-up valve.

Control Panel: UL Listed assembly.

Vent Condenser: Internal type.

Low Water Alarm: Two probe type to stop pump and sound alarm.

Factory Assembly: Complete package system ready for connection of utilities.

Spray Bar: Stainless steel spray bar and nozzles.

Boiler Feed Pumps: See Pump Bulletin.

Water Gauge Glass: Brass safety type with check.

Transfer Pump: Factory mounted, piped and wired.

Temperature Gauge: Two 3" diameter dial type.

Transfer Valve: On K5 systems only.

DK5 & K5 SPLIT TANK ATMOSPHERIC DEAERATOR

DIMENSIONS

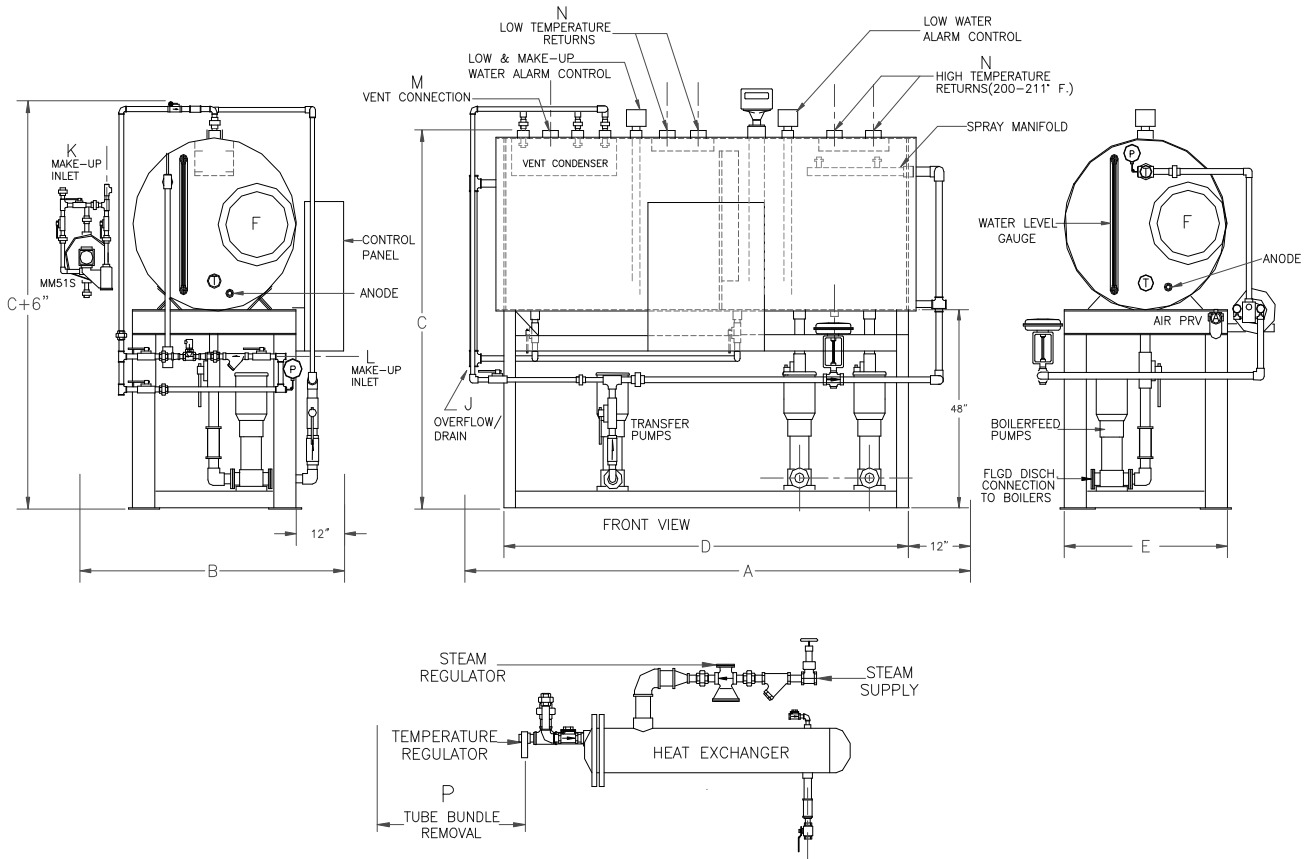

MODEL NUMBER	A	B	C	D	E	F	J	K	N	P
DK5-100	68	62	84	54	36	X	1.25	0.75	1.5	50
DK5-150	68	62	84	54	36	X	1.25	0.75	1.5	62
DK5-200	102	62	84	88	36	X	1.5	0.75	1.5	50
DK5-250	102	62	84	88	36	X	1.5	0.75	2	50
DK5-300	122	64	84	108	36	X	1.5	0.75	2	62
DK5-350	122	64	84	108	36	X	1.5	0.75	2	75
DK5-400	122	70	90	108	42	X	2	0.75	2.5	75
DK5-500	122	79	90	108	48	X	2	0.75	2.5	62
DK5-600	122	79	96	108	48	X	2	0.75	3	75
DK5-800	122	91	108*	108	60	X	2.5	0.75	3	98
DK5-900	122	91	108*	108	60	X	2.5	1	3	88
DK5-1000	122	85	108*	144	54	X	2.5	1	3	88
DK5-1200	158	93	108*	144	60	X	2.5	1	3	88
DK5-1500	158	102	108*	144	66	X	2.5	1.25	4	88
DK5-1800	176	102	114*	162	66	X	2.5	1.25	4	98
DK5-2400	203	108	120*	189	72	X	2.5	1.25	4	98
DK5-3000	230	109	120*	216	72	X	2.5	1.50	4	98
DK5-4500	173	121	132*	259	84	X	4	2	6	98

NOTES:

- (1) Overall dimensions could vary depending on options furnished
- (2) Refer to submittal drawings for system height with condenser.
- (3) See submittal drawing for vent line and steam supply sizes.
- (4) Make-up supply line to valve inlet should be a minimum of one pipe size larger than valve.
- (5) Pump orientation is typical. Quantity and type of pumps will determine final orientation.
- (6) Stand height may increase to accommodate pump NPSH.
- (7) Same dimensions should be used for the same capacity K5 system.
- (8) Insulation not included in width dimensions.

*Consult factory for over height shipping arrangements.

.005 HEATING ASSEMBLY SELECTION

STEP 3

Select a heat exchanger.

Based on the total system capacity and the calculated blend temperature, select a heat exchanger model number from Table I. After a heat exchanger has been selected, enter the model number into the system model number.

EXAMPLE: Based on a 300 HP system and a calculated blend temperature of 115° F: Use a model EF exchanger.

STEP 4

Using the required steam valve flow calculated on page 2, select a steam valve size and model from Table II. Select the valve with a capacity that meets or exceeds the required lbs/hr flow rate based on the supply steam pressure. After steam valve selection enter model number as the last item in the system model number.

EXAMPLE: Based on a required steam flow of 1,161 lbs/hr and a 75 psig supply pressure we would select a model 4 (1") steam valve.

Table I

HEATING ASSEMBLY HEAT EXCHANGER SELECTION CHART								
DA SIZE IN HP	EVAP. RATE GPM	MINIMUM TANK LENGTH	BLEND TEMPERATURE					
			50° F	75° F	100° F	125° F	150° F	175° F
EXCHANGER MODEL NUMBER								
50	3.5	48	CD	EC	CC	CC	CB	CB
100	6.9	48	ED	ED	ED	CD	CC	CC
125	8.6	48	FD	ED	ED	CD	CD	CC
150	10.4	72	EE	EE	ED	CE	CD	CC
200	13.8	60	GD	EE	FD	ED	EC	CD
250	17.3	60	GD	FD	FD	ED	ED	CD
300	20.7	84	FE	FE	EF	EE	ED	CF
350	24.2	84	FF	FE	EF	EE	ED	CF
400	27.6	84	FF	FE	FE	EF	EE	ED
500	34.5	84	GE	FF	FE	EF	EE	ED
600	41.4	84	GF	FG	FF	FE	FD	EF
700	48.3	96	GF	FG	FF	FF	FE	EF
800	55.2	108	FH	FH	FG	FF	FE	EG
900	62.1	108	GG	GF	FG	FF	FG	EG
1000	69.0	108	GG	GG	GF	FG	FF	EH
1200	82.8	96	HG	GG	GG	GF	GE	FF
1500	103.5	108	HG	GH	GG	GG	GE	FG
1800	124.2	120	HH	HH	HG	HF	GH	FH
2000	138.0	120	JH	JG	HG	HF	GH	FH
2100	144.9	120	JH	JG	HG	HF	GH	FH
2400	165.6	189	JH	JH	JG	HG	HG	GG
2500	172.5	189	KG	JH	JG	JF	HG	GG
3000	207.0	216	KH	KG	JH	JG	HH	GH

Table II

HEATING ASSEMBLY STEAM VALVE SELECTION CHART												
CAPACITY IN POUNDS PER HOUR												
STEAM	IPS*	0.5"	0.75"	1"	1.25"	1.5"	2"	2.5"	3"	4" F	6" F	8" F
PRESSURE	MODEL*	2	3	4	5	6	8	10	12	16	24	32
PSIG	Cv*	2.8	5.4	8.8	14.1	19.8	31	44	74	109	248	444
30		150	289	472	759	1,061	1,661	2,358	3,966	5,841	13,290	23,794
40		238	460	750	1,201	1,687	2,641	3,748	6,303	9,284	21,124	37,819
50		313	604	985	1,578	2,216	3,469	4,923	8,280	12,197	27,750	49,682
60		358	690	1,124	1,801	2,529	3,960	5,620	9,453	13,923	31,679	56,715
75		429	828	1,350	2,163	3,037	4,755	6,749	11,351	16,719	38,040	68,104
100		549	1,059	1,726	2,766	3,884	6,080	8,630	14,514	21,379	48,642	87,085
125		669	1,290	2,102	3,368	4,730	7,405	10,511	17,678	26,039	59,244	106,066
150		789	1,521	2,478	3,971	5,576	8,731	12,392	20,841	30,698	69,846	125,047

*Cv = Valve flow coefficient IPS = Valve pipe size Model = Sellers model number

COMPONENT DESCRIPTION

GENERAL DESCRIPTION

The Sellers atmospheric deaerator is an effective boiler feed water system that provides oxygen and carbon dioxide removal to less than .005 cc/liter (7.2ppb). This system operates at atmospheric pressure and maintains a 212 ° F. boiler feed water temperature. This reduces the use of chemicals and increases boiler life. The standard system provides storage, make-up, heating, pumps and controls all in a packaged system.

RECEIVER

The vented receivers are heavy 1/4" minimum PVQ steel. An epoxy phenolic lining and a magnesium anode are included for extra long service life. Receivers are mounted on a welded structural steel stand with integral pump supports. Receivers 36" diameter and larger are furnished with a 16" diameter manhole. Two or more handholes are provided on smaller tanks. Double handholes or manholes are furnished on split tanks. Top inlet openings are equipped with a baffle.

HEATING ASSEMBLY

An externally mounted shell and tube heat exchanger is provided to heat the make-up and return water to 220° degrees F. This water is then admitted to the tank through non-ferrous spray nozzles. This action separates the dissolved air from the feed water and the oxygen and non-condensable gases are vented to atmosphere. A steam control valve and pneumatic thermostat are provided to

maintain water temperature from the exchanger. A condensate line with orifice union returns the exchanger condensate directly to the deaerator receiver.

CONTROLS

Make-up on small systems to 500 HP is admitted through a MM51 float valve. Larger single tank systems include a pneumatic modulating level controller and valve. Electric solenoid valves and probe type level controls are used on larger split tank units. Standard make-up valves are sized for at least 25% of the unit capacity.

Probe type low water cutoffs are provided on all units to protect the pumps. High water controls are optional.

PUMPS

Pumps are single stage or multistage low NPSH centrifugal type designed for heavy duty industrial service. NEMA C flanged ODP driving motors are direct mounted on the pump. Both stainless steel and bronze fitted pumps are used. Liquid tight wiring to the pumps is standard.

CONTROL PANEL

A unitized control panel for all pumps and controls is furnished. Combination motor starters with circuit breakers and overload protection, oil tight switches and lights, color coded wires and numbered terminal strips are included. The panel assembly complies with NEC requirements and is UL Listed.

DEAERATOR INSTALLATION

Sellers deaerators are factory assembled and ready for installation at the jobsite. All components are factory mounted, set and ready for attachment to building utilities. Delicate controls may be removed and packaged separately for safety in shipping. Over height units are match marked and separated for shipping.

Installation requirements include:

Vent line: Direct to outside, full size with no drips or traps.

Make-up: Fresh softened domestic water to make-up inlet.

Condensate returns: To proper connections per instructions.

Drain valve and overflow: To floor drain.

Pumps: Pipe to boilers and include spring loaded check valve and loading valve.

Steam: Provide clean steam with traps and pipe to inlet strainer.

Chemicals: Inject downstream of pumps unless chemical supplier will guarantee no damage to pumps.

Electrical supply: Provide to single point electrical connection on panel.

Air supply: Provide 30 to 100 psi to air filter regulation inlet connection.

See installation instructions for complete details.